

SiPM Power Supply with Temperature Compensation

Lower ripple and temperature compensated

Introduction to SiPM Power Supply Module

The SiPM power supply module consists of two parts: the power supply module main board and the sensor module. The main board includes an analog-to-digital conversion circuit, a MCU circuit, a digital-to-analog conversion circuit, a DC-DC boost circuit, which is for temperature compensation and output voltage control; the sensor module includes a temperature sensor and a SiPM. The temperature sensor detects the temperature of the SiPM operating ambience. The main board and the sensor module are connected by FPC cable. This module not only maintains a stable overvoltage of the SiPM, but also quickly evaluates the performance of the SiPM with temperature compensation.



Main features:

Wide output voltage range: 22V-35V;

Lower ripple voltage noise: <math><5\text{mVp-p}</math>;

Can be used with the JAMP-TN series evaluation board for evaluation and verification;

Fundamental

The frame diagram of the SiPM power supply module is shown below.

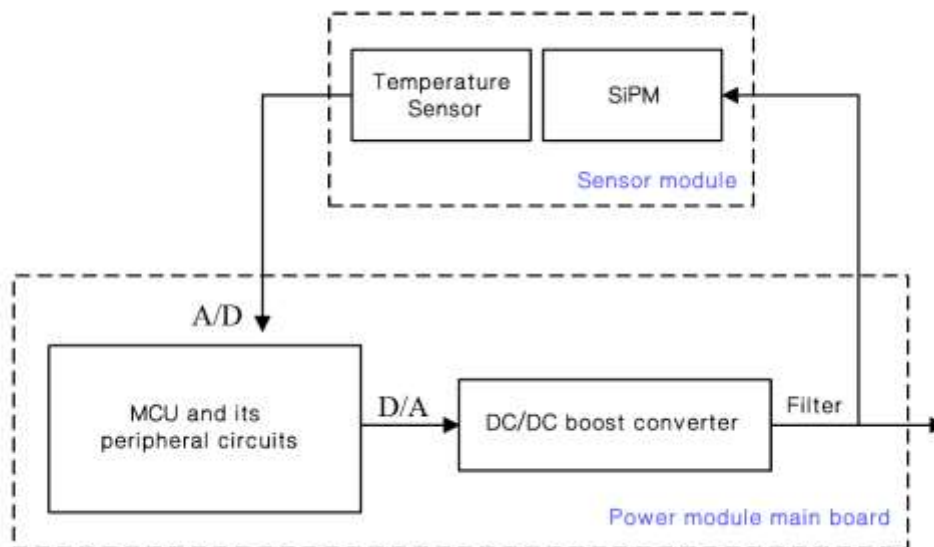

General Parameters

Parameters	Symbol	Test Conditions	Minimum Value	Typical Value	Maximum Value	Unit
Supply Voltage	Vs	-	4.75	5	5.25	V
Output Voltage	Vo	No load	22	-	35	V
Output Current	Io	-	0	-	3	mA
Input Current	Ic	Vo=29V, No load	-	-	<100	mA
Output Ripple	Vn	Vo=29V, No load	-	3.5	5	mV
Operating Temperature Range ¹	Topr	-	-30	-	+60	°C
Storage Temperature Range ¹	Tst	-	-40	-	+85	°C
Main Board Size	-	-	-	30×35	-	mm
Sensor Module Size	-	-	-	12×12	-	mm

¹ When using or storing, please be careful to avoid condensation, so as to avoid damage or failure of the voltage module.

² Unless otherwise notice, the parameters above were obtained at room temperature and a supply voltage of 5V.

Interface Diagram

The SiPM power supply module main board is a circuit board with three SMA connectors and one FPC flexible cable connector. SMA connector are respectively for +5V power supply input terminal Vin, voltage output terminal Bias and the reserved SiPM signal output terminal Bout, FPC soft cable is connected to SiPM power supply module and power board; sensor module has only one FPC soft cable connector; its interface diagram is shown below :

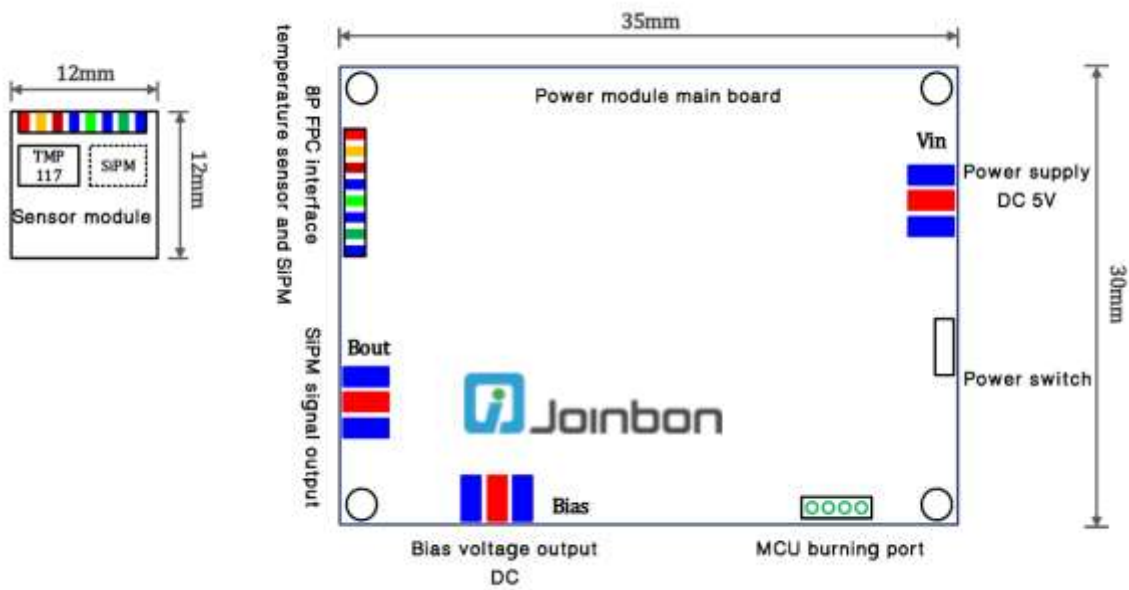

The specific description of each connector is as follows:

Interface Allocation	
ID	Description
Vin	5V Power supply terminal
Bias	Bias voltage output (between 22V and 35V)
Bout	SiPM signal output
FPC Cable	Connect the power supply module main board and sensor module

Characteristic Curve

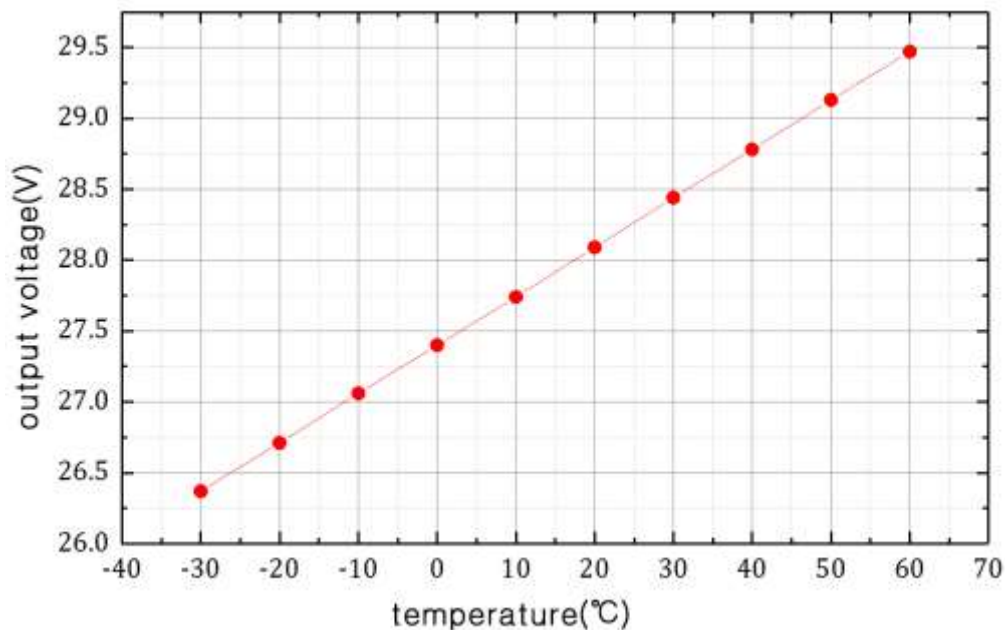

Figure 1 Power supply module output voltage changes with temperature

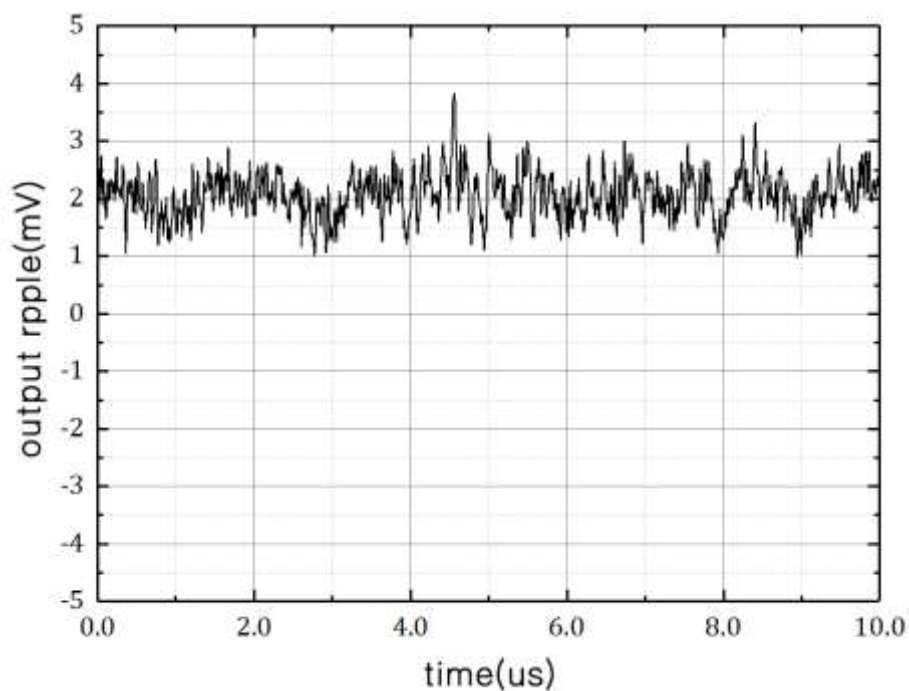

Figure 2 Ripple at output voltage $V_o=29V$ at room temperature

Way of Use

1、 the SiPM power supply module is used alone:

- ① Connect the power input connector “Vin” on the power supply module mainboard to the DC power supply +5V.
- ② Connect the SiPM signal output connector “Bout” on the power supply module main board to the input interface of the instrument, such as the oscilloscope sampling channel interface (requires SMA to BNC cable);
- ③ Connect the sensor module and the power supply module mainboard together through the FPC flexible cable;
- ④ Align the SiPM on the sensor module with the light source and take appropriate shielding methods;
- ⑤ Turn on the +5V input power, turn the power switch on, and observe the SiPM signal on the oscilloscope.

2、 the power supply module is used with the evaluation board:

The temperature compensation power supply module can be used alone or in conjunction with Joinbon’s evaluation board to obtain amplification + temperature compensation:

- ① Connect the power input connector “Vin” on the power supply module mainboard to the DC power supply +5V;
- ② Install and fix the evaluation board in a suitable position, align the front surface of the SiPM with the signal to be measured, and connect the “Bias” port on the power supply module main board to the Bias port of the evaluation board;
- ③ Refer to the evaluation board data sheet to complete the connection of the remaining ports, and connect the amplified signal to the test equipment such as the oscilloscope (requires SMA to BNC cable);
- ④ Connect the temperature sensor module and the power supply module main board together through the FPC flexible cable, and place the temperature sensor near the detector on the evaluation board as close as possible to ensure the accuracy of the temperature obtained by the temperature sensor;
- ⑤ Turn on the +5V input power, turn the power switch on, and observe the SiPM signal on the oscilloscope.

Connection method is shown in Figure 3:

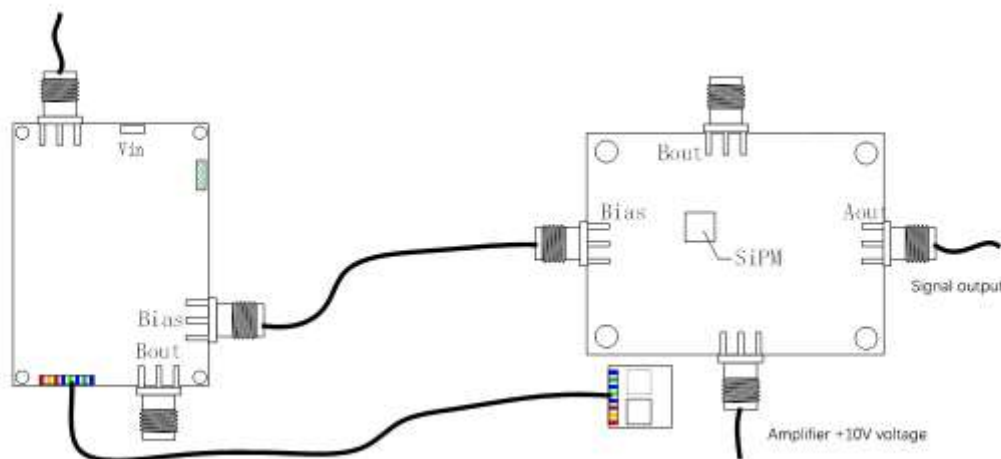

Figure 3 Connecting method of temperature compensation power supply module with evaluation board

Notice:

- ① When connecting the connector of the evaluation board, do not turn on the power to avoid electric shock;
- ② Before turning on the DC power supply, set the output current limit of the DC power supply (such as current limiting 0.1A) to avoid component damage or circuit failure caused by excessive current;
- ③ When the sensor board and power board are not connected, the output voltage of the power board Bias connector is <math><5V</math>;
- ④ If additional replacement of components, lead soldering, etc. are required on the evaluation board, be sure to consult the sales or after-sales personnel to avoid damage to the evaluation board.
- ⑤ When used with the evaluation board, the temperature sensor needs to be placed near the SiPM on the evaluation board, and the temperature environment between the two must not be isolated to ensure that the temperature sensor can obtain the accurate ambient temperature of the SiPM.

■ All specifications are subject to change without notice

Joinbon Technology Co., Ltd. (Hubei)



Building A03, East Lake Hi-Tech Innovation City, No.9 Phoenix Avenue, Phoenix Lake, Ezhou, Hubei, P.R.China.

Postcode: 436060

Tel: 027-5937 0337

Fax: 027-5937 0337

Email: info@joinbon.com

Site: www.joinbon.com